



DC/DC CONVERTER

- 48V DC-Input
- Isolated 48Vdc Output
- Efficiency 95.1%
- Width only 42mm
- 20% Output Power Reserves
- Full Power Between -25°C and +60°C
- Soft-start Function
- Minimal Inrush Current Surge
- Reverse Input Polarity Protection
- 3 Year Warranty

PRODUCT DESCRIPTION

The CD10.482 is a DIN-rail mountable DC/DC converter of the DIMENSION series which provides a floating, stabilized and galvanically separated SELV/PELV output voltage.

The CD-Series is part of the DIMENSION power supply family. The most outstanding features of CD10.482 are the high efficiency, the small size and the wide operational temperature range.

The CD-Series includes all the essential basic functions. The devices have a power reserve of 20% included, which may even be used continuously at temperatures up to +45°C.

High immunity to transients and power surges as well as low electromagnetic emission and a large international approval package for a variety of applications makes this unit suitable for nearly every situation.

SHORT-FORM DATA

Output voltage	DC 48V	Nominal
Adjustment range	48 - 56V	Factory setting 48.0V
Output current	6 - 5.2A	Below +45°C ambient
	5 - 4.3A	At +60°C ambient
	3.8 - 3.2A	At +70°C ambient
	Derate between +60°C and +70°C	
Input voltage	DC 48V	±25%
Input current	5.3A	
Input inrush current	7A peak	
Efficiency	95.1%	
Losses	12.4W	
Hold-up time	7.7ms	
Temperature range	-25°C to +70°C	
Size (W x H x D)	42x124x117mm	Without DIN-rail
Weight	500g / 1.1lb	

ORDER NUMBERS

DC/DC Converter

CD10.482

Mechanical Accessory

ZM2.WALL Wall/panel mount bracket
ZM12.SIDE Side mount bracket

MAIN APPROVALS

For details or a complete approval list see section 18.



INDEX

	Page		Page
1. Intended Use	3	19. Other Fulfilled Standards	16
2. Installation Instructions.....	3	20. Physical Dimensions and Weight	17
3. DC-Input	4	21. Accessories.....	18
4. Input Inrush Current.....	6	21.1. ZM2.WALL – Wall/Panel Mount Bracket.....	18
5. Soft-start Feature	6	21.2. ZM12.SIDE - Side Mount Bracket	19
6. Output.....	7	21.3. YRM2.DIODE - Redundancy Module	20
7. Hold-up Time.....	8	21.4. UF20.481 - Buffer Module.....	20
8. Efficiency and Power Losses.....	9	22. Application Notes.....	21
9. Functional Diagram	10	22.1. Peak Current Capability.....	21
10. Front Side and User Elements	10	22.2. Output Circuit Breakers.....	22
11. Connection Terminals	11	22.3. Charging of Batteries.....	22
12. Lifetime Expectancy	12	22.4. Series Operation.....	23
13. MTBF	12	22.5. Parallel Use to Increase Output Power	23
14. EMC.....	13	22.6. Parallel Use for Redundancy	24
15. Environment.....	14	22.7. Use in a Tightly Sealed Enclosure	25
16. Safety and Protection Features	15	22.8. Mounting Orientations.....	26
17. Dielectric Strength.....	15		
18. Approvals	16		

The information given in this document is correct to the best of our knowledge and experience at the time of publication. If not expressly agreed otherwise, this information does not represent a warranty in the legal sense of the word. As the state of our knowledge and experience is constantly changing, the information in this data sheet is subject to revision. We therefore kindly ask you to always use the latest issue of this document (available under www.pulspower.com).

No part of this document may be reproduced or utilized in any form without our prior permission in writing.

TERMINOLOGY AND ABBREVIATIONS

PE and \oplus symbol	PE is the abbreviation for Protective Earth and has the same meaning as the symbol \oplus .
Earth, Ground	This document uses the term “earth” which is the same as the U.S. term “ground”.
T.b.d.	To be defined, value or description will follow later.
DC 48V	A figure displayed with the AC or DC before the value represents a nominal voltage with standard tolerances included. E.g.: DC 12V describes a 12V battery disregarding whether it is full (13.7V) or flat (10V)
48Vdc	A figure with the unit (Vac) at the end is a momentary figure without any additional tolerances included.
may	A key word indicating flexibility of choice with no implied preference.
shall	A key word indicating a mandatory requirement.
should	A key word indicating flexibility of choice with a strongly preferred implementation.

1. INTENDED USE

This device is designed for installation in an enclosure and is intended for commercial use, such as in industrial control, process control, monitoring and measurement equipment or the like.

Do not use this device in equipment where malfunction may cause severe personal injury or threaten human life.

2. INSTALLATION INSTRUCTIONS



WARNING

Risk of electrical shock, fire, personal injury or death.

- Turn power off before working on the device. Protect against inadvertent re-powering.
- Do not modify or repair the unit.
- Do not open the unit as high voltages may present inside.
- Use caution to prevent any foreign objects from entering the housing.
- Do not use in wet locations or in areas where moisture or condensation can be expected.
- Do not touch during power-on, and immediately after power-off. Hot surface may cause burns.

Obey the following installation requirements:

Install device in an enclosure providing protection against electrical, mechanical and fire hazards.

Install the device onto a DIN-rail according to EN 60715 with the input terminals on the bottom of the device. Other mounting orientations require a reduction in output current.

Make sure that the wiring is correct by following all local and national codes. Use appropriate copper cables that are designed for a minimum operating temperature of 60°C for ambient temperatures up to +45°C, 75°C for ambient temperatures up to +60°C and 90°C for ambient temperatures up to +70°C.

Ensure that all strands of a stranded wire enter the terminal connection. Unused screw terminals should be securely tightened.

The device is designed for pollution degree 2 areas in controlled environments. No condensation or frost is allowed.

The enclosure of the device provides a degree of protection of IP20. The enclosure does not provide protection against spilled liquids. The input can be powered from batteries or similar DC sources. The voltage between the input terminals and ground must not exceed 60Vdc continuously.

The input must be powered from a PELV or SELV source or an "Isolated Secondary Circuit" in order to maintain a SELV or PELV output. Check for correct input polarity. The device will not operate when the voltage is reversed.

A disconnecting means shall be provided for the input of the device.

The device is designed as "Class of Protection I" equipment according to IEC 61140. Do not use without a proper PE (Protective Earth) connection.

The device is designed for convection cooling and does not require an external fan. Do not obstruct airflow and do not cover ventilation grid!

The device is designed for altitudes up to 5000m (16400ft). See additional requirements in the product datasheet for use above 2000m (6560ft).

Keep the following minimum installation clearances: 40mm on top, 20mm on the bottom, 5mm left and right side. Increase the 5mm to 15mm in case the adjacent device is a heat source. When the device is permanently loaded with less than 50%, the 5mm can be reduced to zero.

The device is designed, tested and approved for branch circuits up to 50A without additional protection device. If an external fuse is utilized, do not use circuit breakers smaller than 10A B- or C-Characteristic to avoid a nuisance tripping of the circuit breaker.

The maximum surrounding air temperature is +70°C (+158°F). The operational temperature is the same as the ambient or surrounding air temperature and is defined 2cm below the device.

The device is designed to operate in areas between 5% and 95% relative humidity.

3. DC-INPUT

The input can be powered from batteries or similar DC sources and must be a PELV or SELV source or an "Isolated Secondary Circuit" in order to maintain a SELV or PELV output.

Check for correct input polarity. The device will not operate when the voltage is reversed.

DC input	Nom.	DC 48V	±25%
DC input range	Min.	36-60Vdc	Continuous operation
Allowed voltage between input and earth/ground	Max.	60Vdc or 42.2Vac	Continuous operation, according to IEC 62477-1
Allowed input ripple voltage	Max.	10Vpp	In the frequency range from 47 to 500Hz, the momentary input voltage must always be within the specified limits.
Turn-on voltage	Typ.	35Vdc	Steady-state value, see Fig. 3-1
Shut-down voltage	Typ.	31Vdc	Steady-state value, see Fig. 3-1
Input current	Typ.	5.3A	At 48Vdc input and 48V, 5A output load, see Fig. 3-3
	Typ.	7.0A	At 36Vdc input and 48V, 5A output load, see Fig. 3-3
Start-up delay	Typ.	530ms	See Fig. 3-1
Rise time	Typ.	80ms	At 48V, 5A constant current load, 0mF load capacitance, see Fig. 3-2
	Typ.	380ms	At 48V, 5A constant current load, 5mF load capacitance, see Fig. 3-2
Turn-on overshoot	Max.	500mV	See Fig. 3-2
Input capacitance	Typ.	1 650µF	Installed inside the device, external capacitors on the input are allowed without any limitations.
External input protection	See recommendations in chapter 2.		

Fig. 3-1 Input voltage range

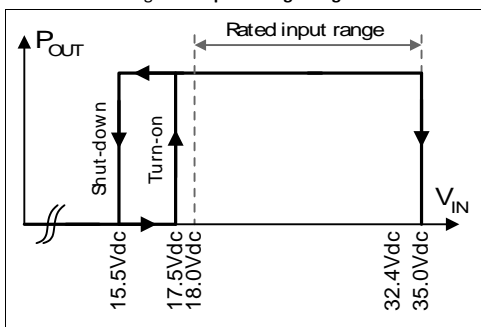

Fig. 3-2 Turn-on behavior, definitions

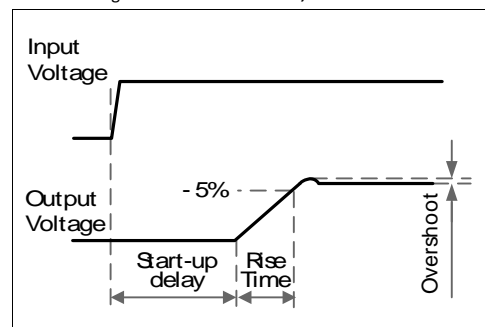
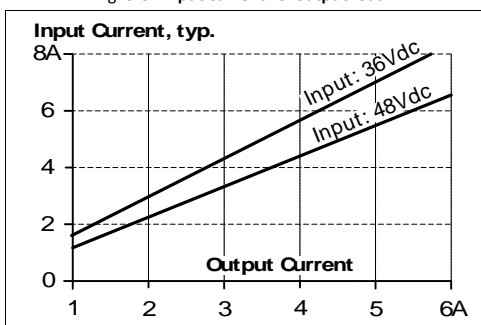

Fig. 3-3 Input current vs. output load



Requirements for the Supplying Source

In certain circumstances, the input filter of the DC/DC converter can show a resonant effect which is caused by the supplying network. Especially when additional external input filters are utilized, a superimposed AC voltage can be generated on the input terminals of the DC/DC converter which might cause a malfunction of the unit. Therefore, additional input filters are not recommended. To avoid the resonant effects, the minimal resistance of the supplying network which depends on the inductance of the input network, shall be above the boundary curve in Fig. 3-4.

Fig. 3-4 External input filter requirements to avoid filter instabilities

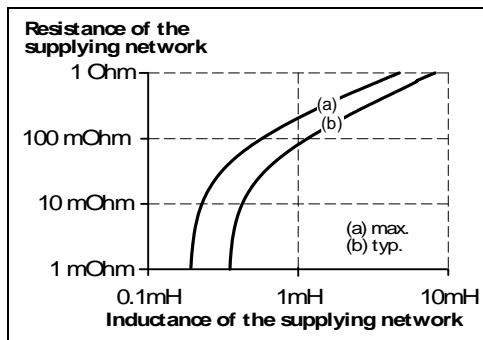

4. INPUT INRUSH CURRENT

An active inrush limitation circuit (inrush limiting NTC resistor which is bypassed by a MOSFET) limits the input inrush current after turn-on of the input voltage.

The charging current into EMI suppression capacitors is disregarded in the first microseconds after switch-on.

Inrush current	Max.	10A _{peak}	Temperature independent
	Typ.	7A _{peak}	Temperature independent
Inrush energy	Max.	1A ² s	Temperature independent

Fig. 4-1 Typical input inrush current behavior at nominal load and 25°C ambient

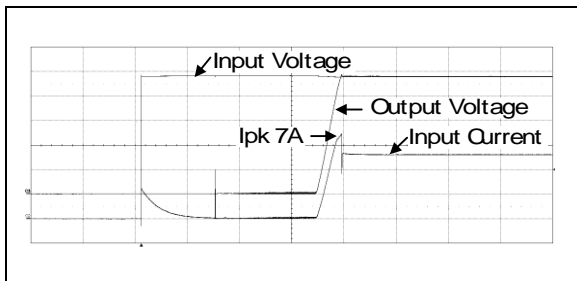

Input: 48Vdc
 Output: 48V, 5A, constant current load
 Ambient: 25°C

Input current 2A / DIV
 Input voltage 10V / DIV
 Output voltage 10V / DIV
 Time basis: 100ms / DIV

5. SOFT-START FEATURE

After the DC/DC converter is turned on, the internal output current rises slowly to its nominal value. This method charges the output capacitors (internal and external capacitors) slowly and avoids high input currents during turn-on. High input currents can produce a high voltage drop on the input wiring (especially with long and thin cables) which reduces the terminal voltage on the DC/DC converter. If the terminal voltage is below the shut-down voltage, the DC/DC converter will turn-off and will make a new start-up attempt. This effect is avoided with the integrated soft-start function. Please note that this function increases the rise time of the output voltage by a small amount.

6. OUTPUT

The output provides a SELV/PELV rated voltage, which is galvanically isolated from the input voltage and is designed to supply any kind of loads, including unlimited capacitive and inductive loads.

The output is electronically protected against overload, no-load and short-circuits. In case of a protection event, audible noise may occur.

The input voltage must also fulfill the SELV/PELV requirements.

Output voltage	Nom.	48V	
Adjustment range	Min.	48-56V	Guaranteed value
	Max.	58.0V	This is the maximum output voltage which can occur at the clockwise end position of the potentiometer due to tolerances. It is not a guaranteed value which can be achieved.
Factory setting		48.0V	±0.2%, at full load, cold unit
Line regulation	Max.	50mV	Between 36 and 60Vdc input voltage variation
Load regulation	Max.	200mV	Between 0 and 5A load variation, static value
Ripple and noise voltage	Max.	100mVpp	Bandwidth 20Hz to 20MHz, 50Ohm
Output current	Nom.	6A	At 48V and an ambient temperature below +45°C
	Nom.	5A	At 48V and +60° ambient temperature
	Nom.	3.8A	At 48V and +70° ambient temperature
	Nom.	5.2A	At 56V and an ambient temperature below +45°
	Nom.	4.3A	At 56V and +60° ambient temperature
	Nom.	3.2A	At 56V and +70° ambient temperature
Overload behavior		Continuous current	
Overload/ short-circuit current	Max.	9A	RMS current, short circuit impedance <90mOhm
Output capacitance	Typ.	1 750µF	Included inside the power supply
Back-feeding loads	Max.	63V	The unit is resistant and does not show malfunctioning when a load feeds back voltage to the power supply. It does not matter whether the power supply is on or off. The absorbing energy can be calculated according to the built-in large sized output capacitor.

Fig. 6-1 Output voltage vs. output current at 48Vdc input voltage, typ.

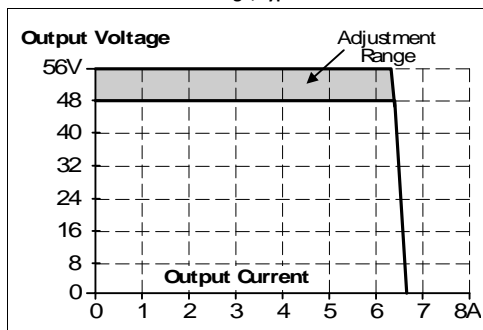
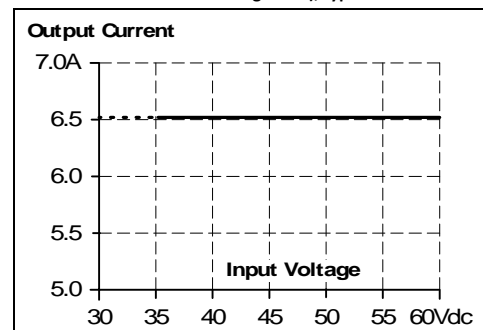

Fig. 6-2 Current limitation vs. input voltage, (46V constant voltage load), typ.



7. HOLD-UP TIME

The input side of the DC/DC converter is equipped with a bulk capacitor which keeps the output voltage alive for a certain period of time when the input voltage dips or is removed. The bulk capacitor can be discharged by loading the DC/DC converter on the output side or through a load which is parallel to the input. There is no protection in the DC/DC converter which prevents current from flowing back to the input terminals. If prevention is needed, an external diode should be used.

At no load, the hold-up time can be up to several seconds. The green DC-ok lamp is also on during this time.

Hold-up Time	Typ.	14ms	At 48Vdc input voltage, 48V, 2.5A output, see Fig. 7-1
	Min.	11ms	At 48Vdc input voltage, 48V, 2.5A output, see Fig. 7-1
	Typ.	7.7ms	At 48Vdc input voltage, 48V, .5A output, see Fig. 7-1
	Min.	6.2ms	At 48Vdc input voltage, 48V, 5A output, see Fig. 7-1

Fig. 7-1 Hold-up time vs. input voltage

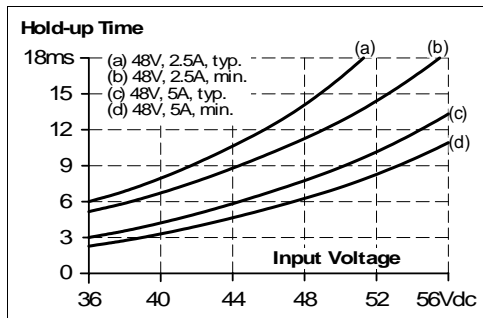

Fig. 7-2 Shut-down test setup

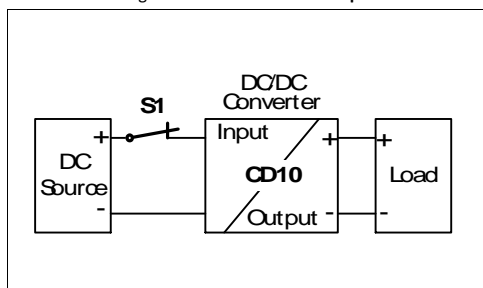
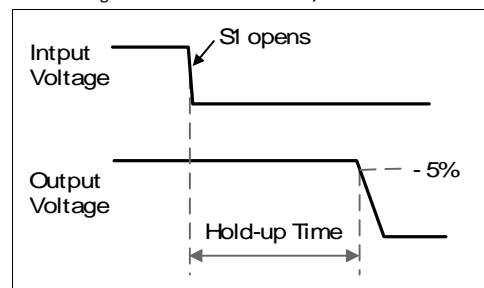

Fig. 7-3 Shut-down behavior, definitions



8. EFFICIENCY AND POWER LOSSES

Input 48Vdc			
Efficiency	Typ.	95.1%	At 48V, 5A
	Typ.	94.9%	At 48V, 6A (Power Boost)
Average efficiency*)	Typ.	94.6%	At 25% at 1.25A, 25% at 2.5A, 25% at 3.75A. 25% at 5A
Power losses	Typ.	2.1W	At no output load
	Typ.	6.7W	At 48V, 2.5A
	Typ.	12.4W	At 48V, 5A
	Typ.	15.5W	At 48V, 6A

*) The average efficiency is an assumption for a typical application where the power supply is loaded with 25% of the nominal load for 25% of the time, 50% of the nominal load for another 25% of the time, 75% of the nominal load for another 25% of the time and with 100% of the nominal load for the rest of the time.

Fig. 8-1 Efficiency vs. output current at 48V output and 48Vdc input voltage, typ.

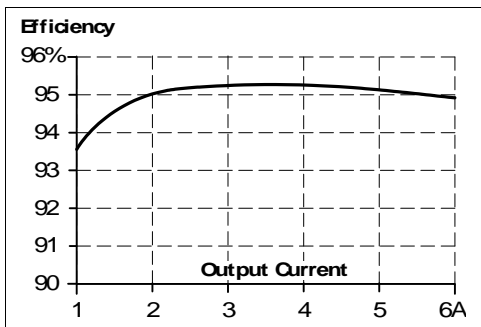

Fig. 8-2 Losses vs. output current at 48V output and 48Vdc input voltage, typ.

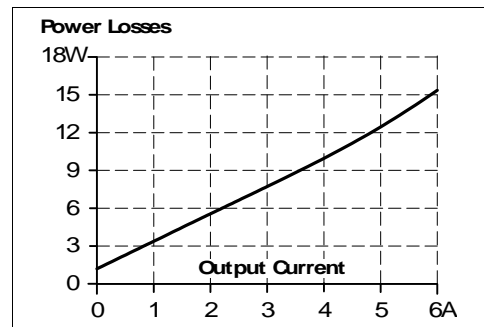

Fig. 8-3 Efficiency vs. input voltage at 48V, 10A, typ.

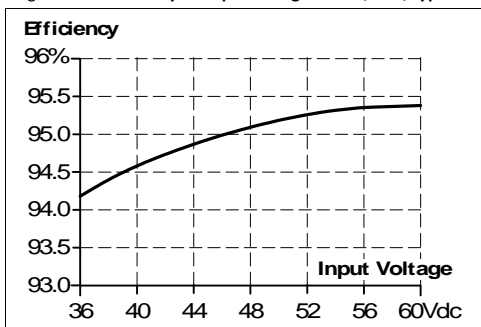
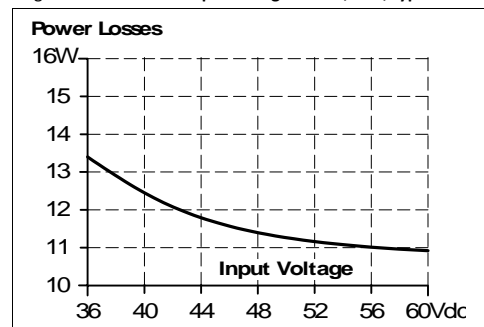
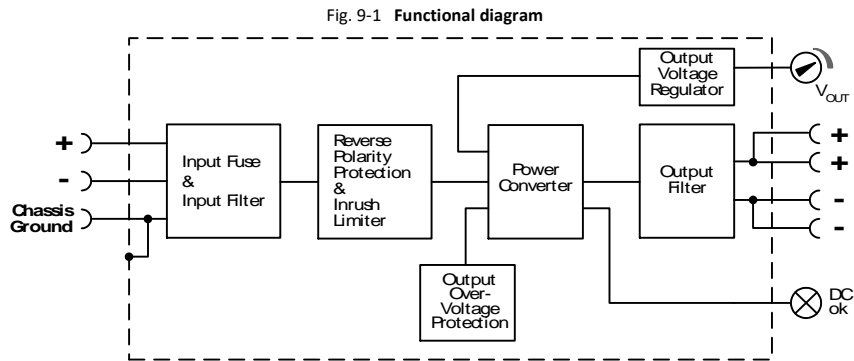

Fig. 8-4 Losses vs. input voltage at 48V, 10A, typ.



9. FUNCTIONAL DIAGRAM



10. FRONT SIDE AND USER ELEMENTS

Fig. 10-1 Front side



- A** Input terminals
 - + Positive input
 - Negative / return input
 Chassis ground: to bond the housing to ground, PE or Functional Earth
- B** Output terminals
 - + Positive output (two identical + poles)
 - Negative / return output (two identical - poles)
- C** Output voltage potentiometer
 - Open the flap to set the output voltage. Factory set: 48.0V
- D** DC-OK LED (green)
 - On when the voltage on the output terminals is > 40V

11. CONNECTION TERMINALS

The terminals are IP20 Finger safe constructed and suitable for field- and factory wiring.

	Input	Output
Type	Screw terminals	Screw terminals
Solid wire	Max. 6mm ²	Max. 6mm ²
Stranded wire	Max. 4mm ²	Max. 4mm ²
American Wire Gauge	20-10 AWG	20-10 AWG
Max. wire diameter (including ferrules)	2.8mm	2.8mm
Recommended tightening torque	1Nm, 9lb.in	1Nm, 9lb.in
Wire stripping length	7mm / 0.28inch	7mm / 0.28inch
Screwdriver	3.5mm slotted or Phillips No 1	3.5mm slotted or Phillips No 1

Daisy chaining of outputs:

Daisy chaining (jumping from one DC/DC-converter output to the next) is allowed as long as the average output current through one terminal pin does not exceed 25A. If the current is higher, use a separate distribution terminal block.

Fig. 11-1 Daisy chaining of outputs

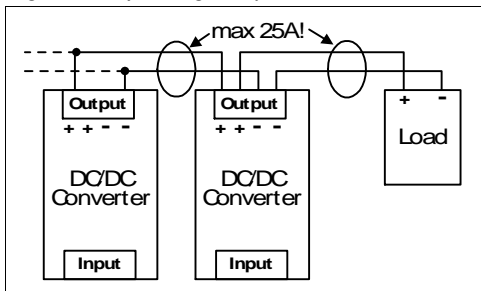
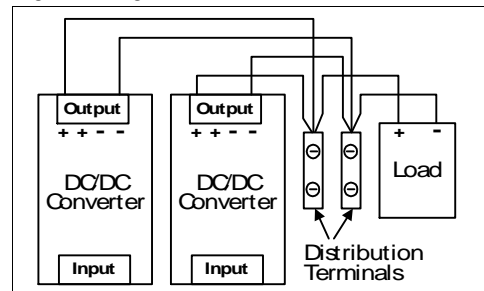

Fig. 11-2 Using distribution terminals



12. LIFETIME EXPECTANCY

The Lifetime expectancy shown in the table indicates the minimum operating hours (service life) and is determined by the lifetime expectancy of the built-in electrolytic capacitors. Lifetime expectancy is specified in operational hours and is calculated according to the capacitor's manufacturer specification. The manufacturer of the electrolytic capacitors only guarantees a maximum life of up to 15 years (131 400h). Any number exceeding this value is a calculated theoretical lifetime which can be used to compare devices.

	Input 48Vdc	
Lifetime expectancy	160 000h	At 48V, 5A and 40°C
	307 000h	At 48V, 2.5A and 40°C
	112 000h	At 48V, 6A and 40°C
	453 000h	At 48V, 5A and 25°C
	868 000h	At 48V, 2.5A and 25°C
	318 000h	At 48V, 6A and 25°C

13. MTBF

MTBF stands for **Mean Time Between Failure**, which is calculated according to statistical device failures, and indicates reliability of a device. It is the statistical representation of the likelihood of a unit to fail and does not necessarily represent the life of a product.

The MTBF figure is a statistical representation of the likelihood of a device to fail. A MTBF figure of e.g. 1 000 000h means that statistically one unit will fail every 100 hours if 10 000 units are installed in the field. However, it can not be determined if the failed unit has been running for 50 000h or only for 100h.

For these types of units the MTTF (**Mean Time To Failure**) value is the same value as the MTBF value.

	Input 48Vdc	
MTBF SN 29500, IEC 61709	853 000h	At 48V, 5A and 40°C
	1 512 000h	At 48V, 5A and 25°C
MTBF MIL HDBK 217F	285 000h	At 48V, 5A and 40°C; Ground Benign GB40
	421 000h	At 48V, 5A and 25°C; Ground Benign GB25
	71 000h	At 48V, 5A and 40°C; Ground Fixed GF40
	97 000h	At 48V, 5A and 25°C; Ground Fixed GF25

14. EMC

The EMC behavior of the device is designed for applications in industrial environment as well as in residential, commercial and light industry environments.

The device is investigated according to the generic standards EN 61000-6-1, EN 61000-6-2, EN 61000-6-3 and EN 61000-6-4.

EMC Immunity

Electrostatic discharge	EN 61000-4-2	Contact discharge	8kV	Criterion A
		Air discharge	15kV	Criterion A
Electromagnetic RF field	EN 61000-4-3	80MHz-2.7GHz	20V/m	Criterion A
Fast transients (Burst)	EN 61000-4-4	Input lines	4kV	Criterion A
		Output lines	2kV	Criterion A
Surge voltage on input	EN 61000-4-5	+ → -	1kV	Criterion A
		+/- → chassis ground	2kV	Criterion A
Surge voltage on output	EN 61000-4-5	+ → -	500V	Criterion A
		+ / - → chassis ground	1kV	Criterion A
Conducted disturbance	EN 61000-4-6	0.15-80MHz	20V	Criterion A

Criteria:

A: The device shows normal operation behavior within the defined limits.

C: Temporary loss of function is possible. The device may shut down and restarts by itself. No damage or hazards for the device will occur.

EMC Emission

Conducted emission on input lines	IEC/CISPR 16-1-2, IEC/CISPR 16-2-1	Limits for DC power networks according to EN 61000-6-3 fulfilled
Radiated emission	EN 55011, EN 55032	Class B

This device complies with FCC Part 15 rules.

Operation is subjected to following two conditions: (1) this device may not cause harmful interference, and (2) this device must accept any interference received, including interference that may cause undesired operation.

Switching Frequency

Main converter	75kHz to 500kHz	Output load and input voltage dependent
----------------	-----------------	---

15. ENVIRONMENT

Operational temperature	-25°C to +70°C (-13°F to 158°F)	The operational temperature is the ambient or surrounding temperature and is defined as the air temperature 2cm below the device.
Storage temperature	-40°C to +85°C (-40°F to 185°F)	For storage and transportation
Output de-rating	3.2W/°C 6W/°C 15W/1000m or 5°C/1000m 9W/-5kPa or 3°C/-5kPa The de-rating is not hardware controlled. The customer has to take care by himself to stay below the de-rated current limits in order not to overload the unit.	Between +45°C and +60°C (113°F to 140°F) Between +60°C and +70°C (140°F to 158°F) For altitudes >2000m (6560ft), see Fig. 15-2 For atmospheric pressures <80kPa, see Fig. 15-2
Humidity	5 to 95% r.h.	According to IEC 60068-2-30
Atmospheric pressure	110-47kPa	See Fig. 15-2 for details
Altitude	Up to 5000m (16 400ft)	See Fig. 15-2 for details
Degree of pollution	2	According to IEC 62477-1, not conductive
Vibration sinusoidal	2-17.8Hz: ±1.6mm; 17.8-500Hz: 2g 2 hours / axis	According to IEC 60068-2-6
Shock	30g 6ms, 20g 11ms 3 bumps / direction, 18 bumps in total Shock and vibration is tested in combination with DIN-Rails according to EN 60715 with a height of 15mm and a thickness of 1.3mm and standard orientation.	According to IEC 60068-2-27
LABS compatibility	As a rule, only non-silicon precipitating materials are used. The unit conforms to the LABS criteria and is suitable for use in paint shops.	
Corrosive gases	Tested according to ISA-71.04-1985, Severity Level G3 and IEC 60068-2-60 Test Ke Method 4 for a service life of minimum 10years in these environments.	
Audible noise	Some audible noise may be emitted from the power supply during no load, overload or short circuit.	

Fig. 15-1 Output current vs. ambient temp.

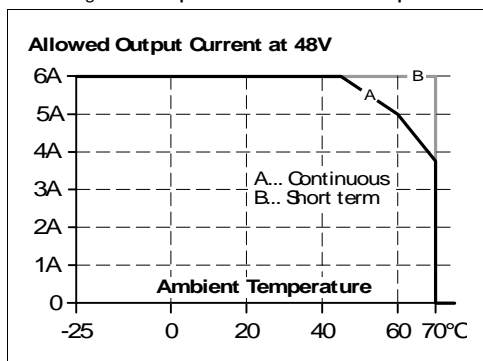
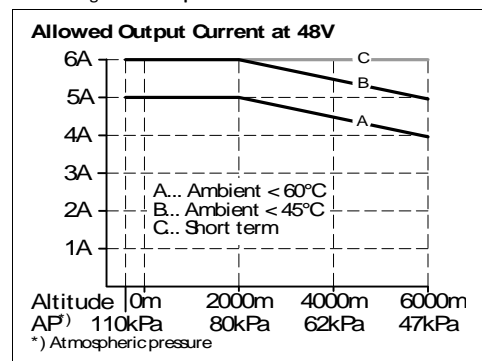

Fig. 15-2 Output current vs. altitude at 48V



16. SAFETY AND PROTECTION FEATURES

Isolation resistance	Min.	500MΩ	At delivered condition between input and output, measured with 500Vdc
	Min.	500MΩ	At delivered condition between input and Chassis Ground, measured with 500Vdc
	Min.	500MΩ	At delivered condition between output and Chassis Ground, measured with 500Vdc
PE resistance	Max.	0.10Ω	Resistance between PE terminal and the housing in the area of the DIN-rail mounting bracket.
Output over-voltage protection	Typ.	58Vdc	In case of an internal defect, a redundant circuit limits the maximum output voltage. The output shuts down and automatically attempts to restart.
	Max.	60Vdc	
Class of protection		I	According to IEC 61140
Degree of protection		IP 20	According to EN/IEC 60529
Over-temperature protection		Not included	
Input transient protection		MOV (Metal Oxide Varistor)	For protection values see chapter 14 (EMC).
Internal input fuse		Included	Not user replaceable slow-blow high-braking capacity fuse
Touch current (leakage current)	The leakage current, which is produced by the DC/DC converter itself, depends on the input voltage ripple and need to be investigated in the final application. For a smooth DC input voltage, the produced leakage current is less than 100μA.		

17. DIELECTRIC STRENGTH

The output voltage is floating and has no ohmic connection to the ground.

The output is insulated to the input by a double or reinforced insulation.

Type and routine tests are conducted by the manufacturer. Field tests may be conducted in the field using the appropriate test equipment which applies the voltage with a slow ramp (2s up and 2s down). Connect all input-terminals together as well as all output poles before conducting the test. When testing, set the cut-off current settings to the value in the table below.

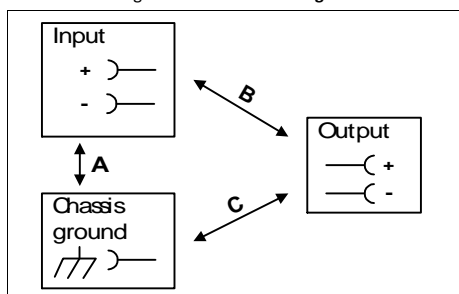

Fig. 17-1 Dielectric strength



		A	B	C
Type test	60s	1500Vac	1500Vac	500Vac
Routine test	5s	1500Vac	1500Vac	500Vac
Field test	5s	1000Vac	1000Vac	500Vac
Cut-off current setting		20mA	15mA	12mA

It is recommend that either the + pole, the – pole or any other part of the output circuit shall be connected to the earth/ground system. This helps to avoid situations in which a load starts unexpectedly or cannot be switched off when unnoticed earth faults occur.

18. APPROVALS

IEC 60950-1 2 nd Edition	IECEE CB SCHEME	CB Scheme, Information Technology Equipment
IEC 61010-2-201 2 nd Edition	IECEE CB SCHEME	CB Scheme for electrical equipment for measurement, control, and laboratory use - Part 2-201: Particular requirements for control equipment
ANSI/UL 61010-2-201 (former UL 508)	 Ind. Cont. Eq.	Listed as Open Type Device for use in Control Equipment UL Category NMTR, NMTR7 E-File: E198865
EN 60079-0, EN 60079-7 ATEX planned	 II 3G Ex ec II TX Gc	Approval for use in hazardous locations Zone 2 Category 3G. Number of ATEX certificate: T.B.D.
IEC 60079-0, IEC 60079-7 planned	IECEX	Suitable for use in Class 1 Zone 2 Groups IIa, IIb and IIc locations. Number of IECEx certificate: T.B.D.

19. OTHER FULFILLED STANDARDS

EC Declaration of Conformity		EU Declaration of Conformity Trade conformity assessment for Europe The CE mark indicates conformance with the European - RoHS directive, - EMC directive, - Low-voltage directive (LVD)
REACH Directive	REACH ✓	Directive 1907/2006/EU of the European Parliament and the Council of June 1 st , 2007 regarding the Registration, Evaluation, Authorisation and Restriction of Chemicals (REACH)

20. PHYSICAL DIMENSIONS AND WEIGHT

Width	42mm 1.65"
Height	124mm 4.88"
Depth	117mm 4.61"
	The DIN-rail height must be added to the unit depth to calculate the total required installation depth.
Weight	500g / 1.10lb
DIN-Rail	Use 35mm DIN-rails according to EN 60715 or EN 50022 with a height of 7.5 or 15mm.
Housing material	Body: Aluminium alloy Cover: zinc-plated steel
Installation clearances	See chapter 2
Penetration protection	Small parts like screws, nuts, etc. with a diameter larger than 3.5mm

Fig. 20-1 Front view

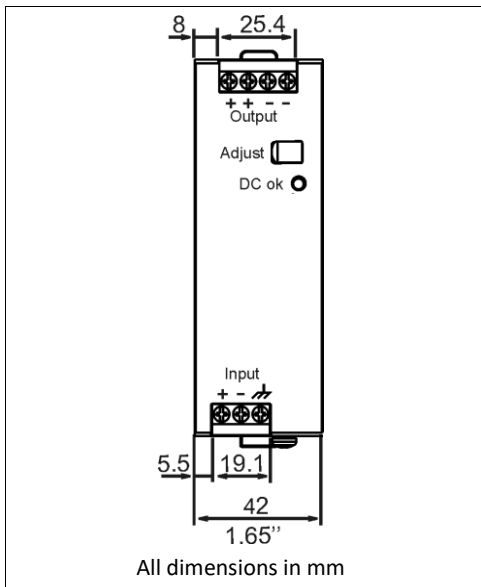
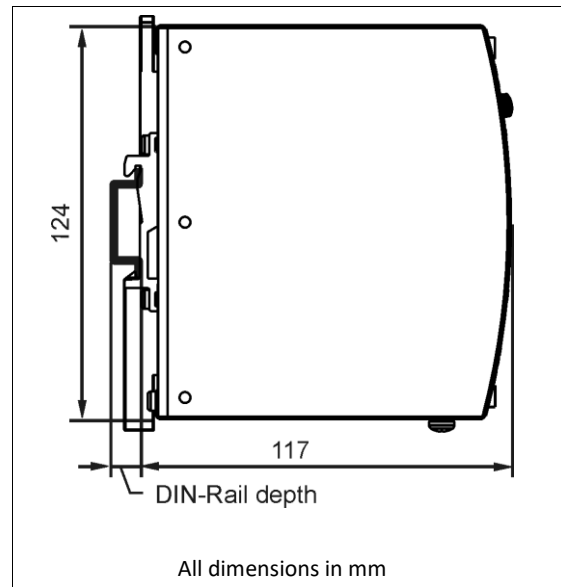

Fig. 20-2 Side view



21. ACCESSORIES

21.1. ZM2.WALL – WALL/PANEL MOUNT BRACKET

These brackets are used to mount the device on a flat surface or panel without utilizing a DIN-rail. The brackets can be mounted without detaching the DIN-rail brackets.

The order number ZM2.WALL contains two brackets needed for one device.

Fig. 21-1 ZM2.Wall



Fig. 21-2 Hole pattern

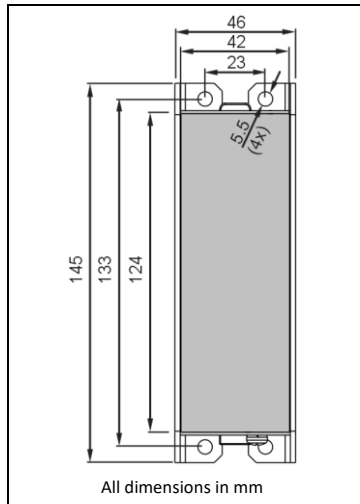

Fig. 21-3 Side view

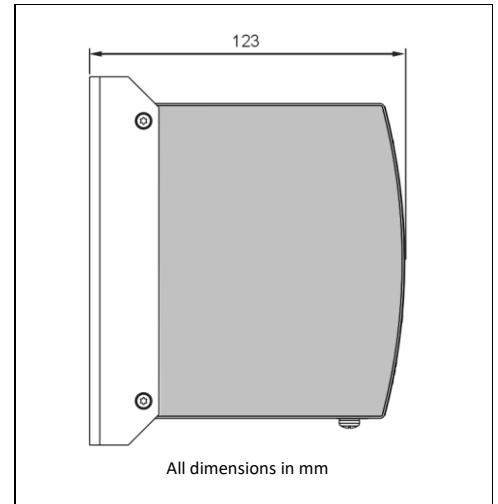

Fig. 21-4 Isometric view

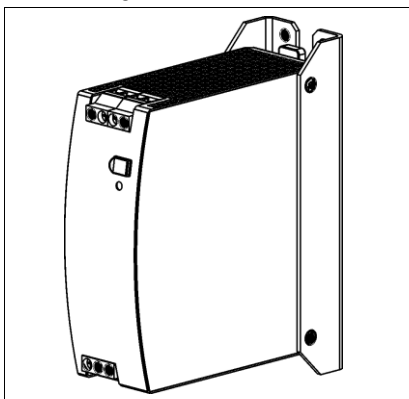

Fig. 21-5 Isometric view

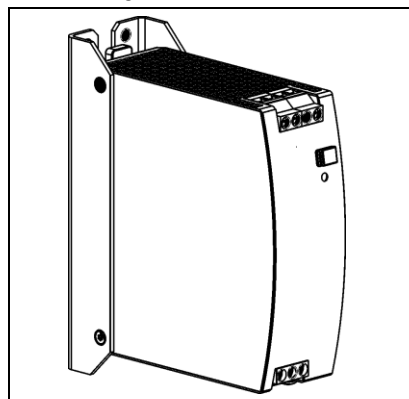
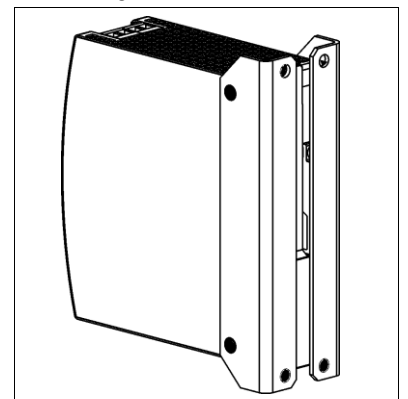

Fig. 21-6 Isometric view



21.2. ZM12.SIDE - SIDE MOUNT BRACKET

This ZM12.SIDE bracket is used to mount the device sideways with or without utilizing a DIN-rail to save installation depth.

The two aluminum brackets and the black plastic slider of the unit have to be detached, so that the ZM12.SIDE steel bracket can be mounted.

For sideways DIN-rail mounting, the removed aluminum brackets and the black plastic slider need to be mounted on the ZM12.SIDE steel bracket.



Fig. 21-7
Side mounting
without DIN-rail brackets

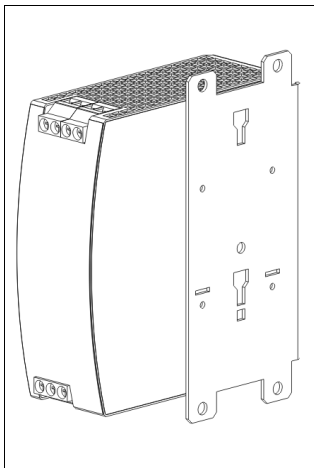

Fig. 21-8
Side mounting
with DIN-rail brackets

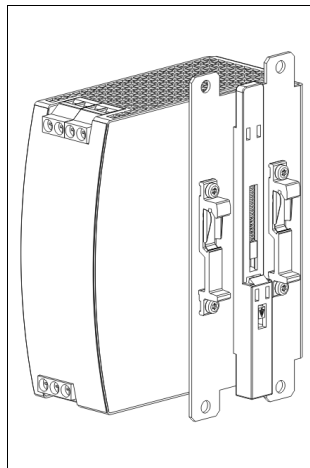
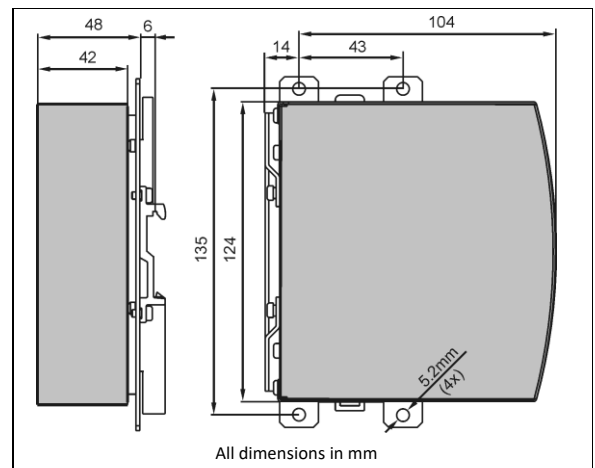

Fig. 21-9
Hole pattern



21.3. YRM2.DIODE - REDUNDANCY MODULE



The YRM2.DIODE is a dual redundancy module, which can be used to build 1+1 or N+1 redundant system.

The device is equipped with two input channels each 10A nominal, which are individually decoupled by utilizing diode technology. The output can be loaded with nominal 20A.

The device does not require an additional auxiliary voltage and is self-powered even in case of a short circuit across the output.

The device has a monitoring circuit included and is the perfect choice when the power supply has no DC-OK function. Two LEDs and two relay contacts signal when one of the two input voltages are not in range due to a non-functioning or disconnected power supply.

The unit is very slender and only requires 32mm width on the DIN-rail.

See chapter 22.6 for wiring information.

21.4. UF20.481 - BUFFER MODULE

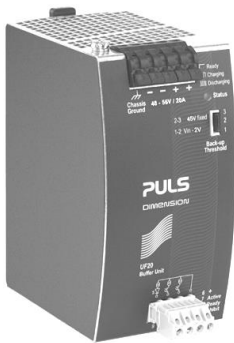

The UF20.481 buffer module is a supplementary device for 48V DC/DC converters. It delivers power to bridge typical supply voltage faults or extends the hold-up time after turn-off of the input power.

In times when the DC/DC converter provides sufficient voltages, the buffer module stores energy in integrated electrolytic capacitors. In case of a supply voltage fault, this energy is released again in a regulated process.

The buffer module does not require any control wiring. It can be added in parallel to the load circuit at any given point.

One buffer module can deliver 20A additional current. Buffer modules can be added in parallel to increase the output ampacity or the hold-up time.

22. APPLICATION NOTES

22.1. PEAK CURRENT CAPABILITY

The unit can deliver peak currents (up to several milliseconds) which are higher than the specified short-term currents.

This helps to start current demanding loads. Solenoids, contactors and pneumatic modules often have a steady state coil and a pick-up coil. The inrush current demand of the pick-up coil is several times higher than the steady-state current and usually exceeds the nominal output current. The same situation applies when starting a capacitive load.

The peak current capability also ensures the safe operation of subsequent circuit breakers of load circuits. The load branches are often individually protected with circuit breakers or fuses. In case of a short or an overload in one branch circuit, the fuse or circuit breaker need a certain amount of over-current to open in a timely manner. This avoids voltage loss in adjacent circuits.

The extra current (peak current) is supplied by the power converter and the built-in large sized output capacitors of the power supply. The capacitors get discharged during such an event, which causes a voltage dip on the output. The following two examples show typical voltage dips:

Fig. 22-1 10A Resistive peak load (2x the nominal current) for 50ms, typ.

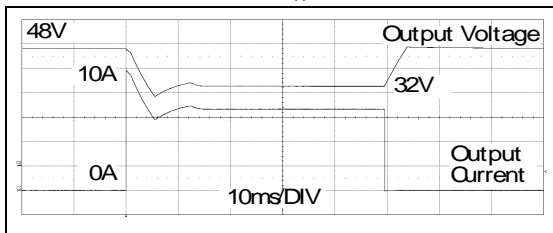
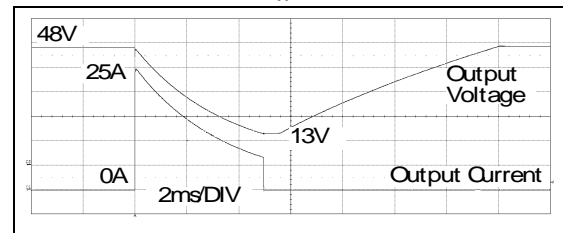

Fig. 22-2 25A Resistive peak load (5x the nominal current) for 5ms, typ.



Peak current voltage dips	typ.	from 48V to 32V	At 10A for 50ms, resistive load
	typ.	from 48V to 28V	At 25A for 2ms, resistive load
	typ.	from 48V to 13V	At 25A for 5ms, resistive load

22.2. OUTPUT CIRCUIT BREAKERS

Standard miniature circuit breakers (MCB's or UL 1077 circuit breakers) are commonly used for AC-supply systems and may also be used on 48V branches.

MCB's are designed to protect wires and circuits. If the ampere value and the characteristics of the MCB are adapted to the wire size that is used, the wiring is considered as thermally safe regardless of whether the MCB opens or not.

To avoid voltage dips and under-voltage situations in adjacent 24V branches which are supplied by the same source, a fast (magnetic) tripping of the MCB is desired. A quick shutdown within 10ms is necessary corresponding roughly to the ride-through time of PLC's. This requires power supplies with high current reserves and large output capacitors. Furthermore, the impedance of the faulty branch must be sufficiently small in order for the current to actually flow. The best current reserve in the power supply does not help if Ohm's law does not permit current flow. The following table has typical test results showing which B- and C-Characteristic MCBs magnetically trip depending on the wire cross section and wire length.

The following test results indicate the maximal wire length for a magnetic (fast) tripping. The wire length is always two times the distance to the load (+ and - wire).

Fig. 22-3 Test circuit for maximum wire length

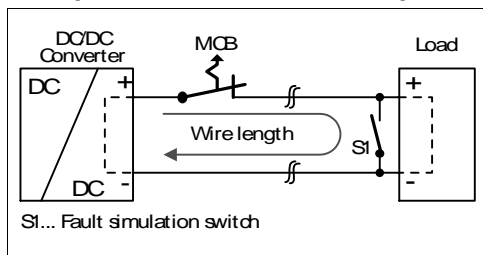

Test results for maximum wire length:

	0.75mm ²	1.0mm ²	1.5mm ²	2.5mm ²
C-2A	43m	54m	82m	117m
C-3A	21m	28m	41m	66m
C-4A	9m	11m	15m	23m
C-6A	3m	3m	4m	6m
B-6A	11m	13m	20m	30m
B-10A	2m	2m	3m	4m

22.3. CHARGING OF BATTERIES

The device can be used to charge lead-acid or maintenance free batteries. Four 12V SLA or VLRA batteries are needed in series connection.

Instructions for charging batteries:

- Ensure that the ambient temperature of the Device is below 45°C.
- Set output voltage, measured at no load and at the battery end of the cable, very precisely to the end-of-charge voltage.

End-of-charge voltage	55.6V	55.0V	54.3V	53.6V
Battery temperature	10°C	20°C	30°C	40°C

- Use a 10A circuit breaker or blocking diode between the Device and the battery.
- Ensure that the output current of the Device is below the allowed charging current of the battery.
- Use only matched batteries when putting 12V types in series.
- The return current to the Device (battery discharge current) is typ. 6mA when the Device is switched off (except in case a blocking diode is utilized).
- Do not use the devices for battery charging in mounting orientations other than the standard mounting orientation or in any other condition where a reduction of the output current is required (e.g. altitude).

22.4. SERIES OPERATION

Devices of the same type can be connected in series for higher output voltages. It is possible to connect as many units in series as needed, providing the sum of the output voltage does not exceed 150Vdc. Voltages with a potential above 60Vdc must be installed with a protection against touching.

Avoid return voltage (e.g. from a decelerating motor or battery) which is applied to the output terminals.

Keep an installation clearance of 15mm (left / right) between two power supplies and avoid installing the power supplies on top of each other. Do not use power supplies in series in mounting orientations other than the standard mounting orientation.

Pay attention that EMI and inrush current will increase when using multiple devices.

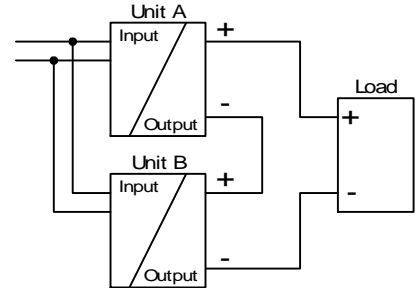

22.5. PARALLEL USE TO INCREASE OUTPUT POWER

Devices can be paralleled to increase the output power. The output voltage shall be adjusted to the same value ($\pm 100\text{mV}$) with the same load conditions on all devices, or the devices can be left with the factory settings.

The ambient temperature is not allowed to exceed $+45^\circ\text{C}$.

If more than three devices are connected in parallel, a fuse or circuit breaker with a rating of 10A is required on each output. Alternatively, a diode or redundancy module can also be utilized.

Keep an installation clearance of 15mm (left / right) between two devices and avoid installing devices on top of each other. Do not use devices in parallel in mounting orientations other than the standard mounting orientation or in any other condition where a reduction of the output current is required (e.g. altitude).

Pay attention that EMI and inrush current will increase when using multiple devices.

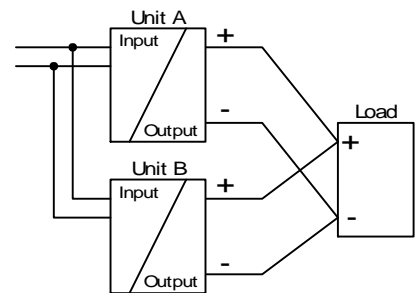

22.6. PARALLEL USE FOR REDUNDANCY

1+1 Redundancy:

Devices can be paralleled for redundancy to gain higher system availability. Redundant systems require a certain amount of extra power to support the load in case one device fails. The simplest way is to put two devices in parallel. This is called a 1+1 redundancy. In case one device fails, the other one is automatically able to support the load current without any interruption. It is essential to use a redundancy module to decouple devices from each other. This prevents that the defective unit becomes a load for the other device and the output voltage cannot be maintained any more.

1+1 redundancy allows ambient temperatures up to +70°C.

Pay attention that EMI and inrush current will increase when using multiple devices.

Recommendations for building redundant power systems:

- Use separate input fuses for each device.
- Use separate supply systems for each device whenever it is possible.
- Monitor the outputs of the individual devices. Use the DC-ok lamp or the DC-ok contact, which are included in the redundancy module YRM2.DIODE.
- It is desirable to set the output voltages of all devices to the same value ($\pm 100\text{mV}$) or leave it at the factory setting.

N+1 Redundancy:

Redundant systems for a higher power demand are usually built in a N+1 method. E.g. four devices, each rated for 10A are paralleled to build a 30A redundant system.

Pay attention that EMI and inrush current will increase when using multiple devices.

Keep an installation clearance of 15mm (left / right) between two devices and avoid installing the devices on top of each other.

Do not use devices in parallel in mounting orientations other than the standard mounting orientation or in any other condition, where a reduction of the output current is required.

For N+1 redundancy the ambient temperature is not allowed to exceed +45°C.

Wiring examples for 1+1 and n+1 redundancy:

Fig. 22-4 1+1 Redundant configuration for 5A load current with a dual redundancy module

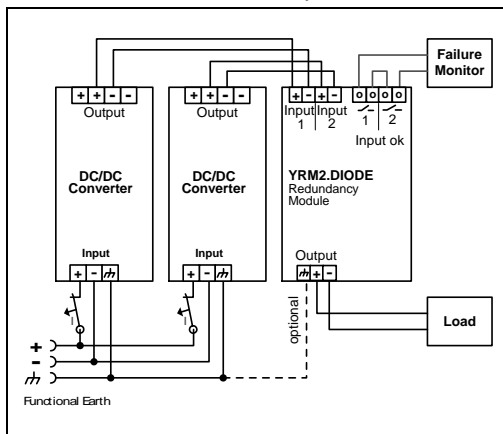
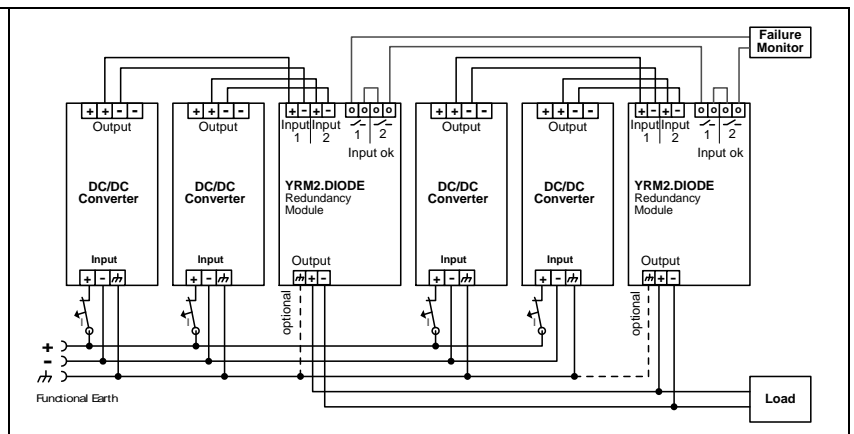

Fig. 22-5 N+1 Redundant configuration for 15A load current with multiple DC/DC converters and redundancy modules



22.7. USE IN A TIGHTLY SEALED ENCLOSURE

When the device is installed in a tightly sealed enclosure, the temperature inside the enclosure will be higher than outside. In such situations, the inside temperature defines the ambient temperature for the device.

In the following test setup, the device is placed in the middle of the enclosure; no other heat producing items are inside the enclosure. The load is placed outside the enclosure.

The temperature sensor inside the enclosure is placed in the middle of the right side of the device with a distance of 1cm. The following measurement results can be used as a reference to estimate the temperature rise inside the enclosure.

	Case A	Case B
Enclosure size	110x180x165mm Rittal Typ IP66 Box PK 9516 100, plastic	110x180x165mm Rittal Typ IP66 Box PK 9516 100, plastic
Input voltage	48Vdc	48Vdc
Load	48V, 4A; (=80%)	48V, 5A; (=100%)
Temperature inside the box	43.5°C	48.1°C
Temperature outside the box	26.2°C	26.6°C
Temperature rise	17.3K	21.5K

22.8. MOUNTING ORIENTATIONS

Mounting orientations other than input terminals on the bottom and output on the top require a reduction in continuous output power or a limitation in the maximum allowed ambient temperature.

The listed lifetime and MTBF values from this datasheet apply only for the standard mounting orientation.

The following curves give an indication for allowed output currents for altitudes up to 2000m (6560ft).

Fig. 22-6
Mounting
Orientation A
(Standard
orientation)

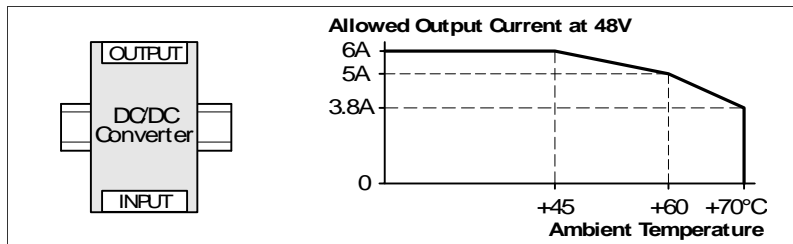

Fig. 22-7
Mounting
Orientation B
(Upside down)

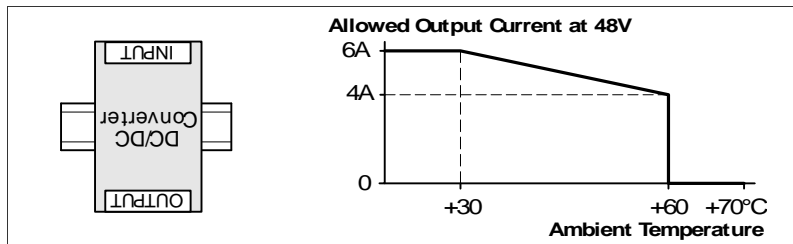

Fig. 22-8
Mounting
Orientation C
(Table-top
mounting)

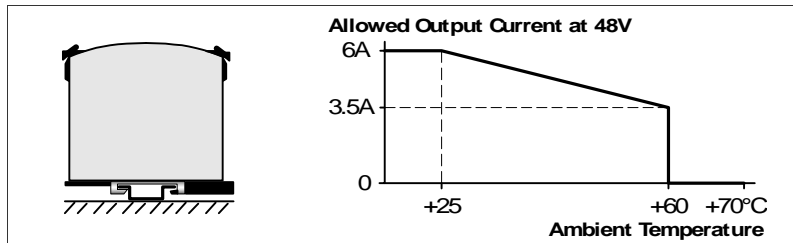

Fig. 22-9
Mounting
Orientation D
(Horizontal cw)

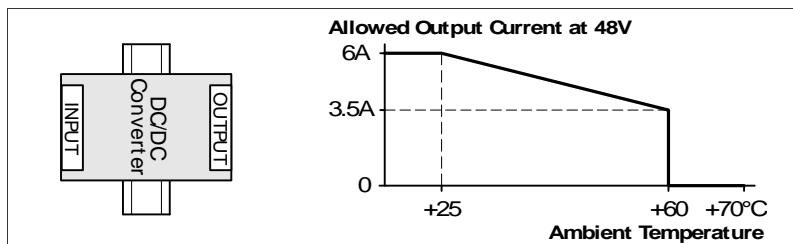

Fig. 22-10
Mounting
Orientation E
(Horizontal ccw)

