

SEMI F47-0706

Voltage Sag Immunity Compliance Certificate *PULS ML50.100 and ML50.109*

Input: AC100-240V 1-phase
Output: 50W, 24V, 2.1A

ML50.109 is identical to the ML50.100 aside from a conformal coated PC-board

Description: Power Supply 24Vdc

Manufacturer: PULS GmbH

Manufacturer Address: Arabellastraße 15, 81925 München

Test Date and Location: 2 April 2007, 942 Corridor Park Blvd, Knoxville, TN 37932 USA

Tested configuration: 100% load, 50/60 Hz at 120/208 Vac, 1-Phase 2-wire +PE, S/N 3516551

Pass/Fail criteria: Full rated output power and continuous processing during all voltage sags.

Certification:

1. Power Standards Laboratory certifies that the above power supply meets the requirements of SEMI F47-0706 for voltage sag immunity when tested according to the procedures set forth in IEC 61000-4-34. An IPC Voltage Sag Generator was used for the testing that fully complies with IEC 61000-4-34.



PULS ML50.100 Power Supply

Power Standards Lab
PSL.
SEMI F47



Andreas Eberhard 16 January 2012
Power Standards Lab

Attachment A – SEMI F47 Test Results

Testing was performed at EPRI’s Power Quality Laboratory in Knoxville, TN. To ensure maximum accuracy of the test, a variable voltage source was used to set the voltage to exactly 120/208Vac. This was verified at the power supply with a qualified meter. During the voltage sag test, the power supply was connected to a variable resistive load bank and loaded to 100% of its load. Table A-1 shows the power supplies rated full load conditions, and the actual load it was tested at.

Table A-2 lists all points tested per SEMI F47-0706. Figure A-1 shows the power supplies ride-through curve at 120Vac. Figure A-2 shows the power supplies ride-through curve at 208Vac. The specific SEMI F47 test points are highlighted for both 50 and 60 Hz. The power supply was tested at points below the curve to fully characterize the components. During the testing of SEMI F47 test points (1s at 80%, 0.5s at 70%, and at 50%) the output voltage of the power supply did not deviate. The power supply passed at 50 and 60 Hz, loaded to 100% of resistive load.

Table A-1 Power Supplies Ratings

Evaluated at 120/208Vac							
Manufacture	Power Supply	Vdc	I	R	W	Actual load	Result
PULS	ML50.100	24	2.1A	11.8Ohm	50	100%	Passed

Table A-2. PULS ML50.100 Test Results

Duration				Percent of Nominal					
Seconds	60Hz Cycles	Seconds	50Hz Cycles	120Vac 60Hz	120Vac 50Hz	208Vac 60Hz	208Vac 50Hz	SEMI F47	Results
1	60	1	50	45%	45%	25%	25%	80%	Passed
0.5	30	0.5	25	45%	45%	25%	25%	80%	Passed
0.5	30	0.5	25	45%	45%	25%	25%	70%	Passed
0.25	15	0.25	12.5	45%	45%	25%	25%	70%	Passed
0.2	12	0.2	10	45%	45%	25%	25%	70%	Passed
0.2	12	0.2	10	45%	45%	25%	25%	50%	Passed
0.17	10	0.17	8.5	45%	45%	20%	25%	50%	Passed
0.15	9	0.15	7.5	45%	45%	0%	0%	50%	Passed
0.08	5	0.08	4	45%	45%	0%	0%	50%	Passed
0.07	4	0.07	3.5	45%	45%	0%	0%	50%	Passed
0.05	3	0.05	2.5	40%	45%	0%	0%	50%	Passed
0.03	2	0.03	1.5	0%	0%	0%	0%	50%	Passed
0.02	1	0.02	1	0%	0%	0%	0%	50%	Passed

Figure A-1. PULS M50.100 SEMI F47 Ride-Through Curve at 120Vac, 50 Hz and 60 Hz

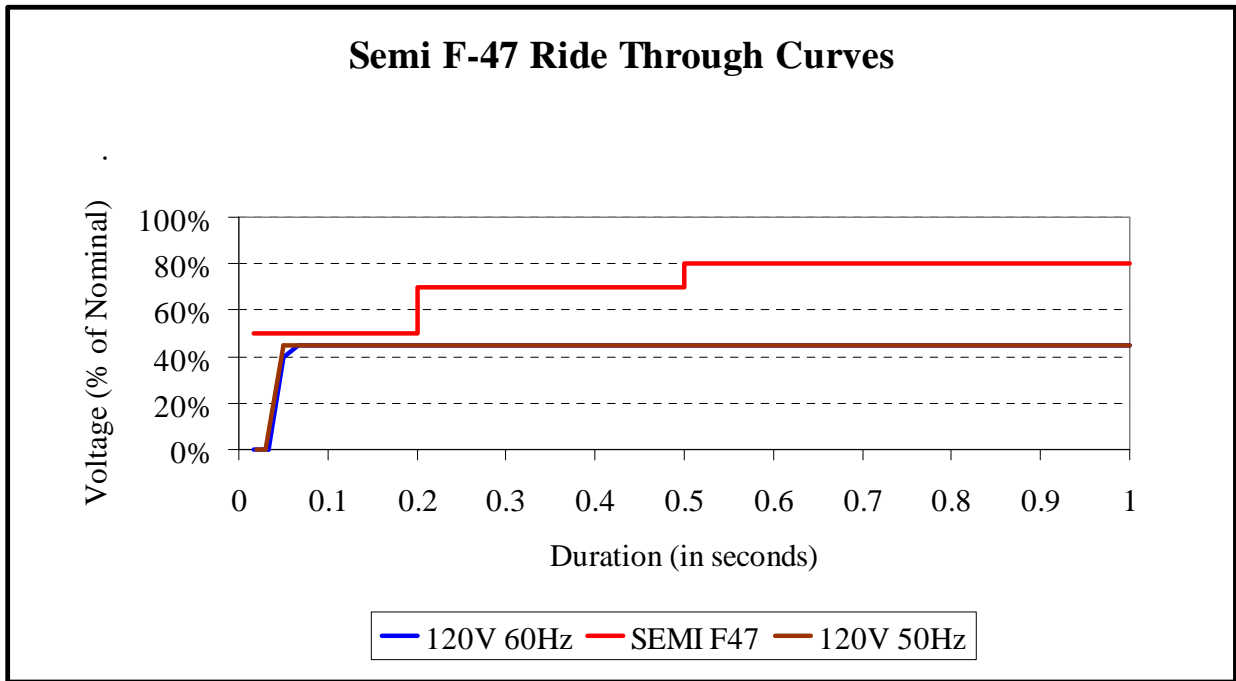
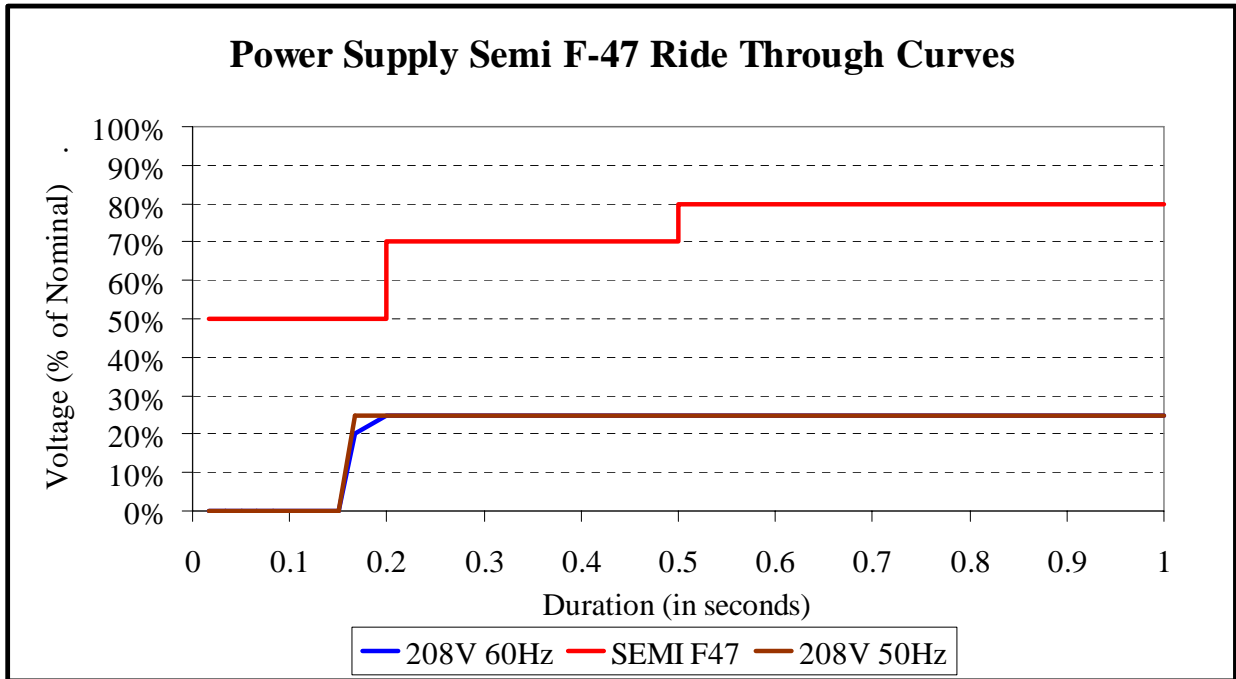

Figure A-2. PULS M50.100 SEMI F47 Ride-Through Curve at 208Vac, 50Hz and 60 Hz



Electrical Environment

Steady state measurements were taken prior to testing. Table A-3 lists measurements taken to characterize the electrical environment of the power supply during SEMI F47 compliance testing, at 50/60 Hz.

**Table A-3. Steady State Measurements for PULS
ML50.100**

Measurement Parameters	Test Process State	Test Process State	Test Process State	Test Process State
	120V/60Hz	120V/50 Hz	208V/60Hz	208V/50Hz
Rated Voltage P-P	100-240	100-240	100-240	100-240
Voltage (Va-b)	120.6	120.8	209	209
Current (Ia)	0.78	0.79	0.59	0.58
Power (Wa-n)	51	50	50	50
Volt Amps (VA)	94	100	120	120
Vthd (Phase A) %	3	3.8	3.1	3.4
Ithd (Phase A) %	83.9	84.2	91.5	91.2
I1	0.42	0.42	0.24	0.24
I3	0.38	0.39	0.23	0.22
I5	0.3	0.29	0.2	0.19
Power Factor	0.54	0.53	0.4	0.41
Crest Factors	2.75	2.64	2.5	2.49
Hertz	60	50	60	50

Attachment B - Test Configuration

Test Configuration

The voltage sag generator was placed in series with the main power feed as shown in Figure B-1. The Main power feed for this test was an amplifier that was adjustable for voltage and frequency. This allowed a precise setting of 120/208Vac and 50/60 Hz. A photo of the setup is shown in Figure B-2.

Figure B-1 – Test Configuration and Setup

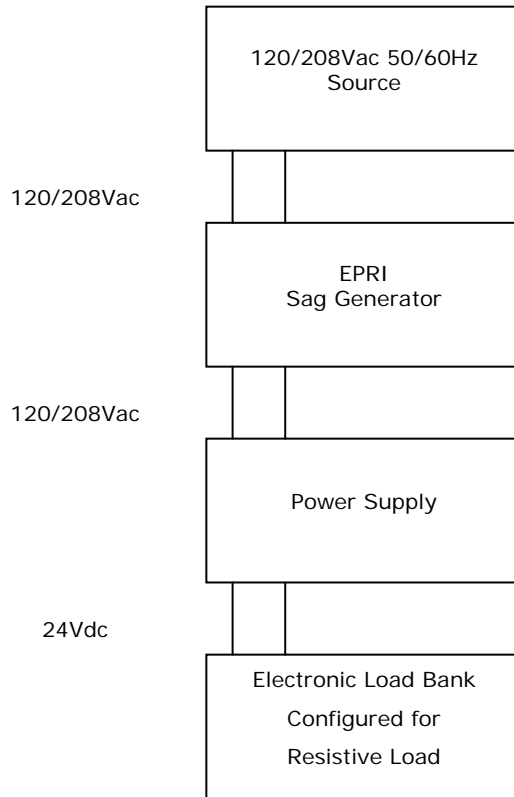

Figure B-2 - Photo of Test Setup

